

## Being in the Comfort Zone

Your comfort zone is where you can function with the least amount of stress to your body.  
(Above the knees and below the shoulders.)

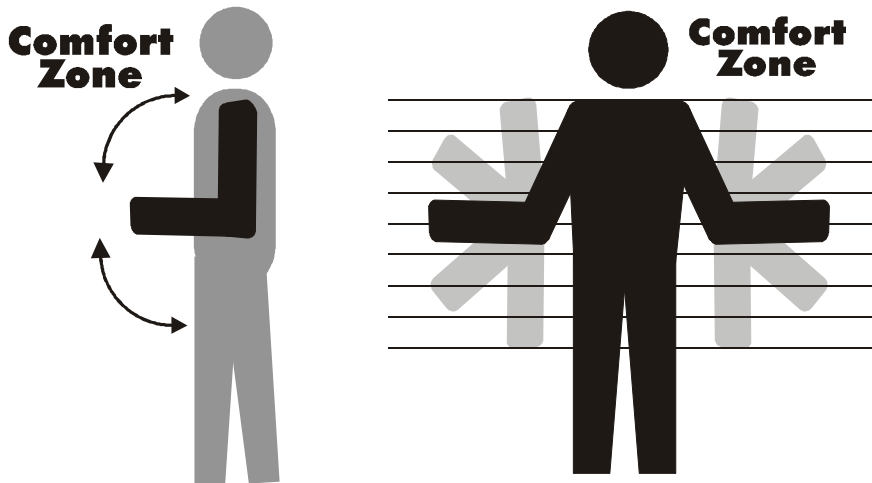

To visualize your COMFORT ZONE, do the following without straightening your elbows.

Bend your elbows at 90 degrees.

1. Keep your arms against your body and move them side to side.
2. Keep your arms against your body and reach as high as you can go.
3. Keep your arms against your body and reach as low as you can go.

That is your comfort zone.

In Part from Public Domain NIOSH: Elements of Ergonomics Program

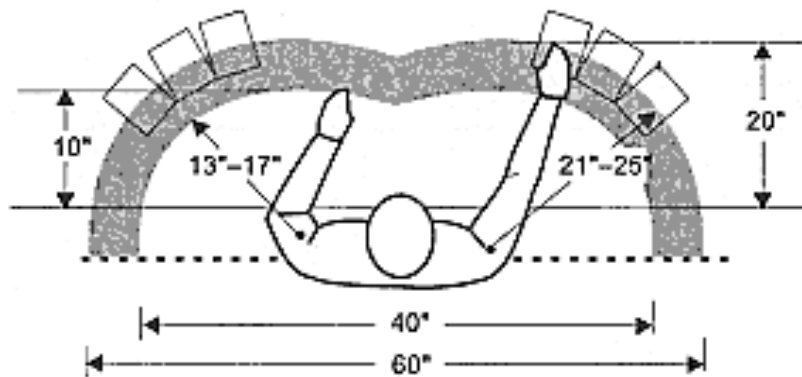

## Neutral Position

Our strongest and most efficient posture is in neutral position where muscles are near the midpoint of their full range.

1. Keep the natural S curves of the spine intact
2. Keep the nose with the toes (Ear, shoulder & hip should form 3 points along a relatively straight line).
3. Keep head and neck upright and relaxed, arms held naturally at the side with the shoulders relaxed and elbows close to the body.
4. There is NO one perfect posture all day. Movement and variety is essential for health.
5. Keep wrists in neutral alignment.
6. Avoid the extremes in joint ranges.

